

Sonoff 4CH Pro (R2) User Guide

Hi, welcome to use Sonoff 4CH Pro! Sonoff 4CH Pro is a 4 channel din rail mounting 433MHz RF remote WiFi switch that can independently control the 4 home appliances. It supports switching among 3 working modes: inching/interlock/self-locking mode.

Power supply: 90-250v AC(50/60Hz)/5-24v DC. Max current: 10A/gang.

1. Download “eWeLink” app.



Search “eWeLink” in APP Store for iOS version or Google play for Android version.

2. Wiring instruction

If you want to connect the Sonoff 4CH Pro with lights or appliances. Please strictly follow the wiring diagram as shown below:

WHAT'S ON BOARD?

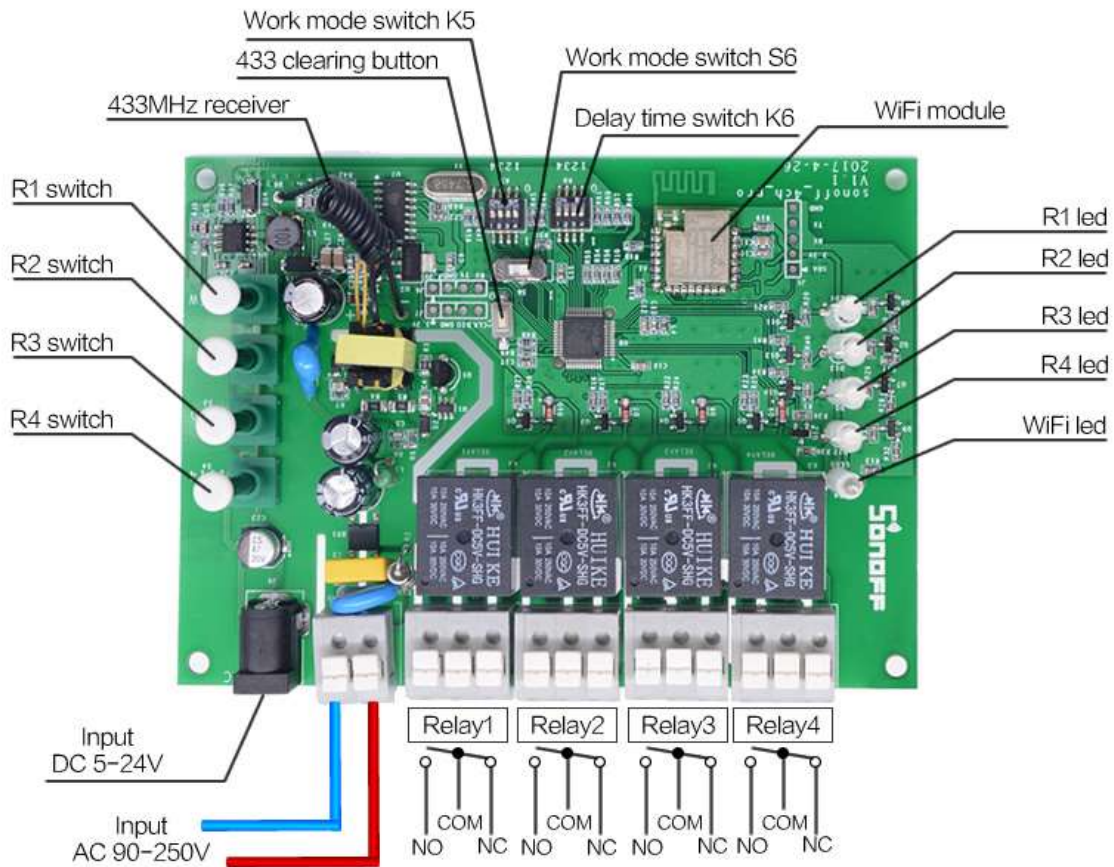

You may choose to power up by 5-24V DC or by 90-250V AC. Each relay without voltage output.

R1-R4 work as local control switches, you can directly press it to turn on/off the corresponding gang. They also work as pairing button.

If you connect the Sonoff 4CH Pro with a motor, the wiring instruction is as below:

AC Motor Wiring Diagram

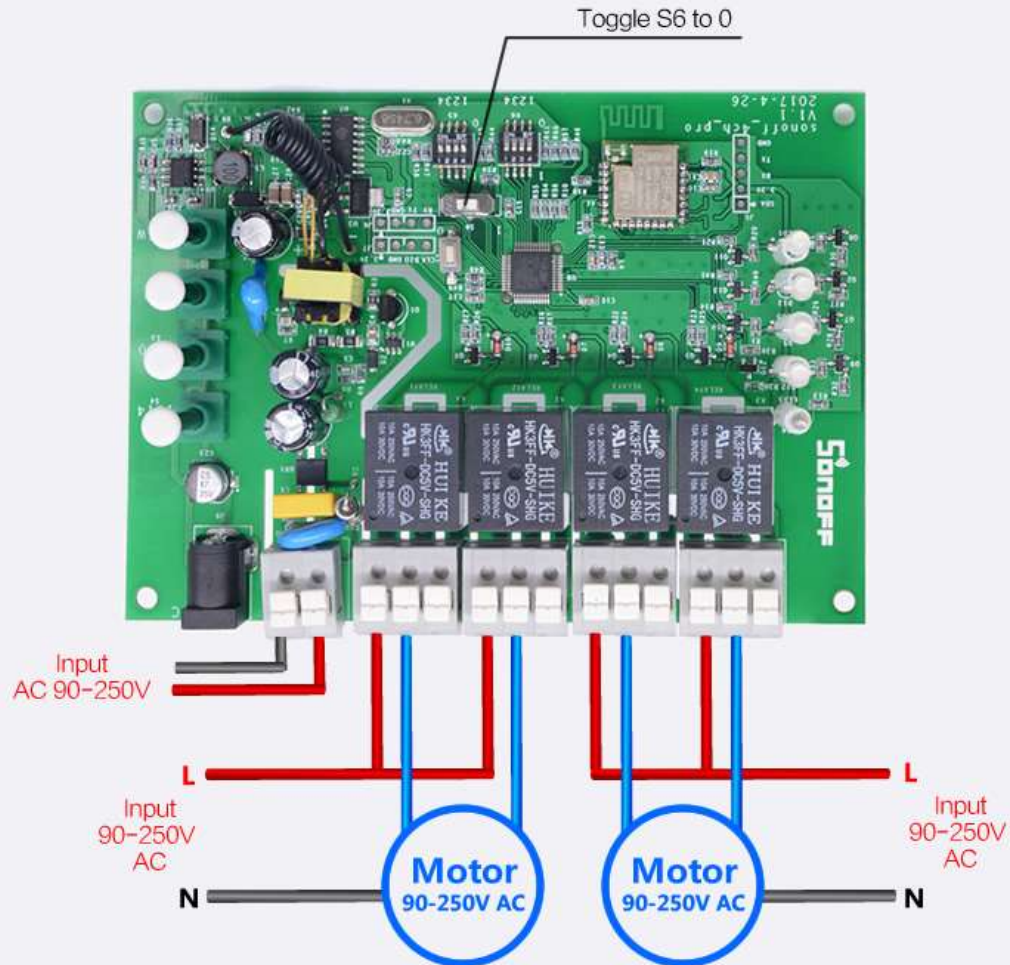

DC Motor Wiring Diagram

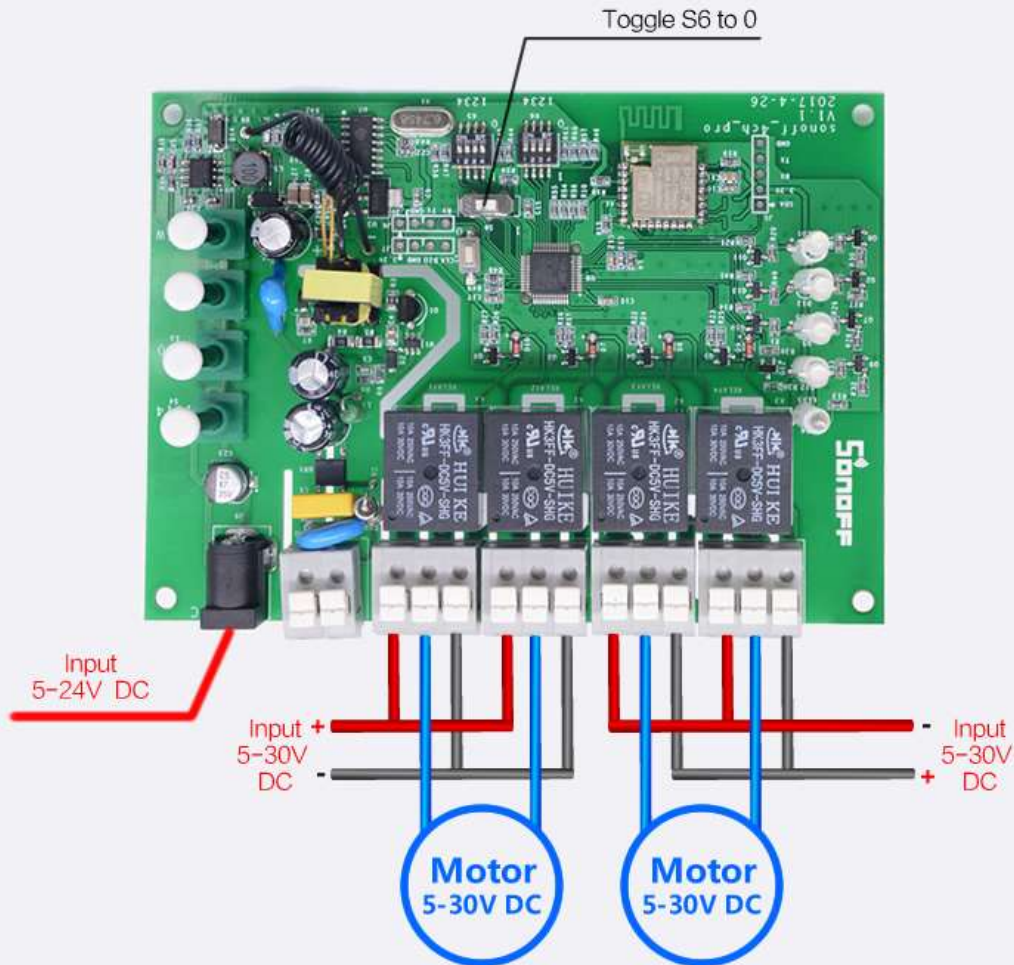

Note : only 1 motor can run each time.

WiFi Remote Controller

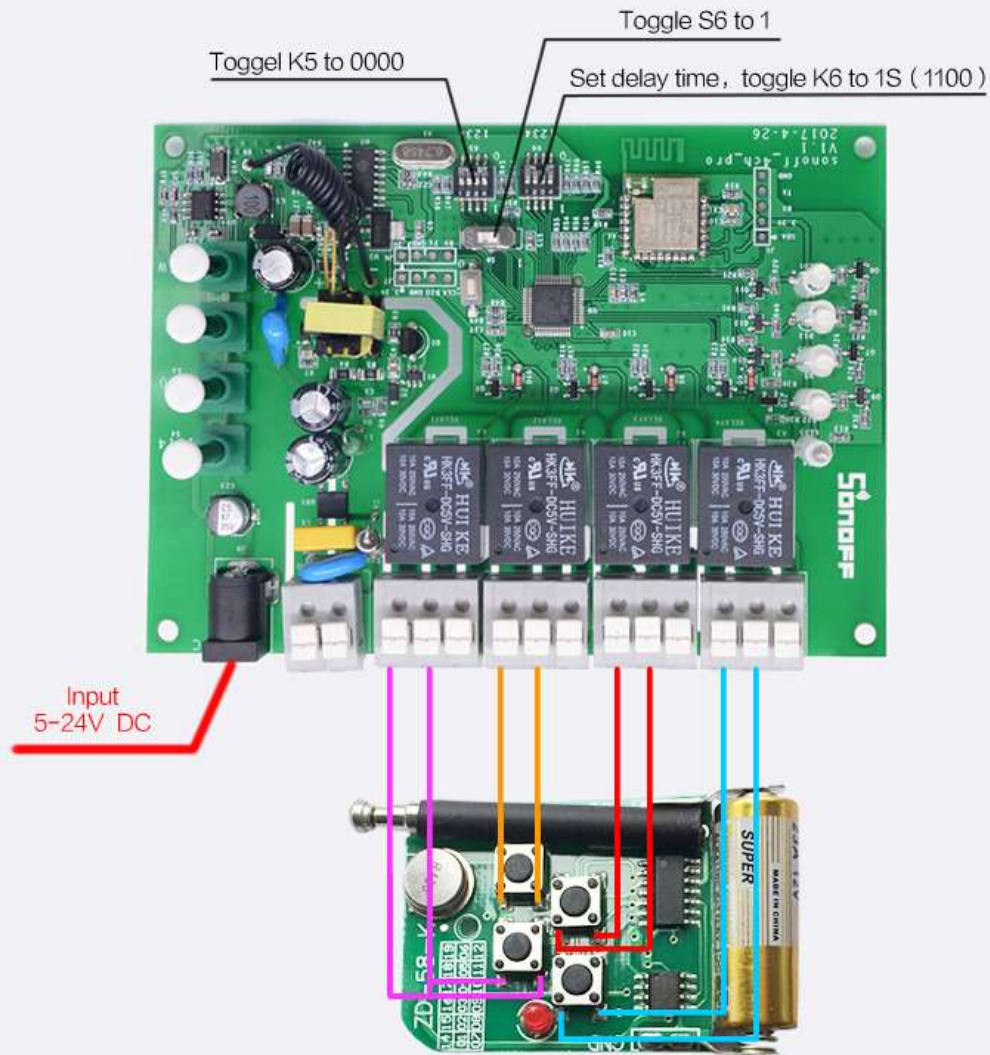

[Working Mode Settings](#)
[RF Remote Settings](#)

3. Add Device

1. Power up your device through 90-250v AC(50/60Hz) or 5-24v DC.

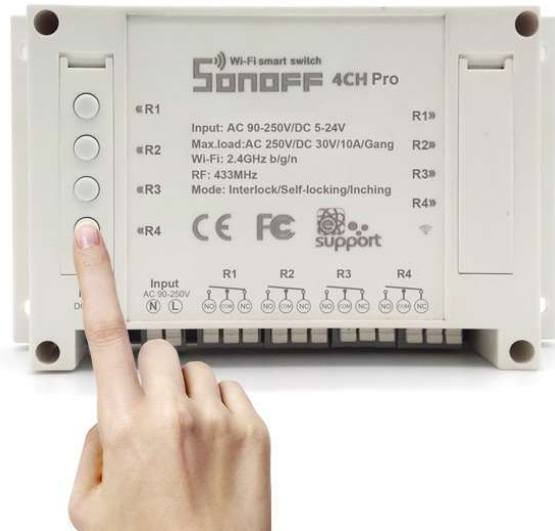

2. Press and hold one of the 4 switch buttons for 7 seconds until the wifi LED fast blinks 3 times and repeats. ●



3. Click the “+” icon on eWeLink to search device, select the corresponding pairing icon, click next.

The App will auto-search the device.



4. Enter your home SSID & password:

4.1 If your WiFi doesn't have a password, keep it blank.

4.2 Now eWeLink only support 2.4G wifi communication protocol, 5G-WiFi-router is not supported

It takes 3 minutes , please wait..



searching device...

5. Next, the device will be registered by eWelink and add it to your account , it takes 1-3 minutes.



6. Name the device to complete.

7. Maybe the device is “Offline” on eWeLink, for the device needs 1 minute to connect to your router and server. When the wifi LED is on, the device is “Online”.

3. Working Mode Settings

You can set the switch among 3 working modes: inching/interlock/self-locking mode.

1. In self-locking mode, you can turn on/off the 4 connected devices independently. For example, if you turn on CH1, connected device keeps on. If you turn off CH2, connected device keeps off.

Self-locking Mode + Inching Mode GIF

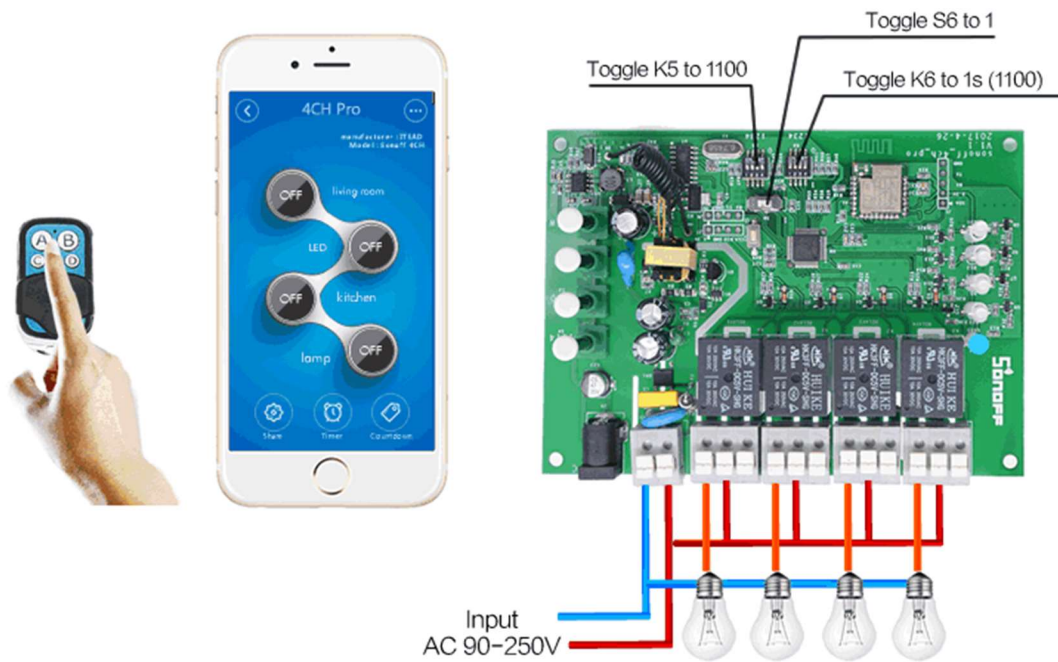

2. In inching mode, you can turn on the connected devices for 1-16s . For example, you can turn on CH1 connected device for 1s, then auto-off.

3 WORKING MODES

③ Inching Mode GIF

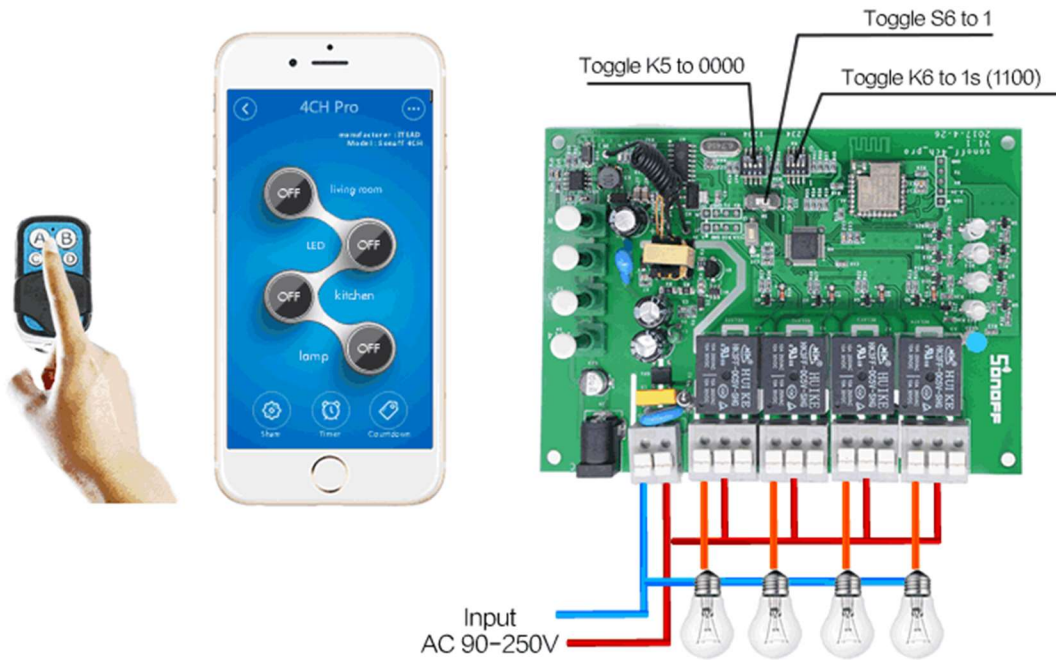

3. In interlock mode, you can turn on 1 device every time, and turn off other devices at the same time. For example, if you have turned on CH2, then when you turn on CH3, CH2 will be auto-turned off at the same time.

3 WORKING MODES

② Interlock Mode GIF

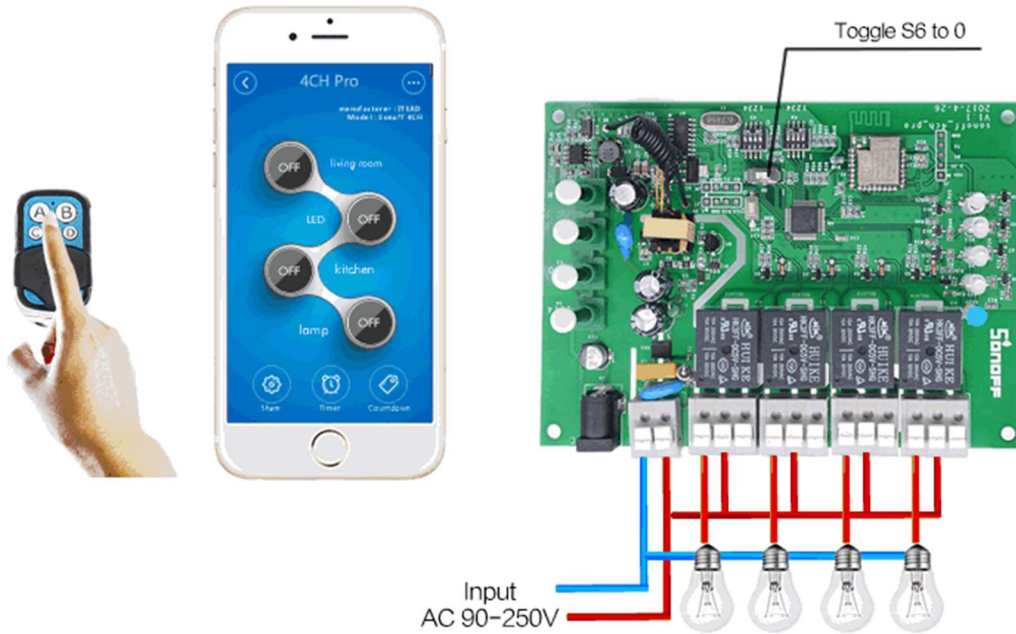

Self-locking Mode + Inching Mode GIF

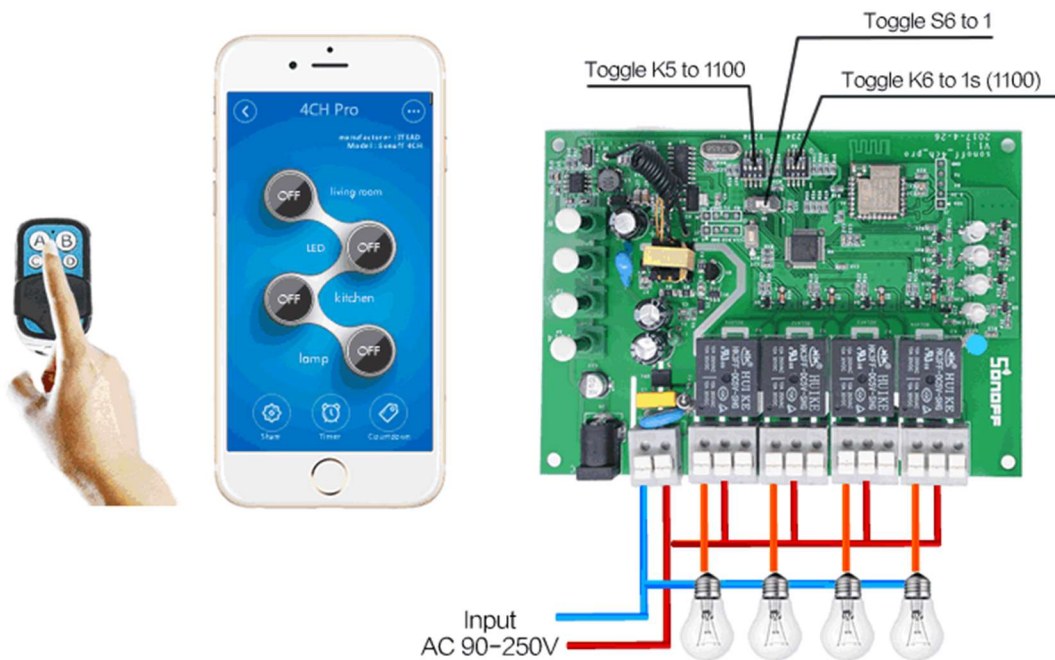

We will introduce how to switch among the 3 modes below:

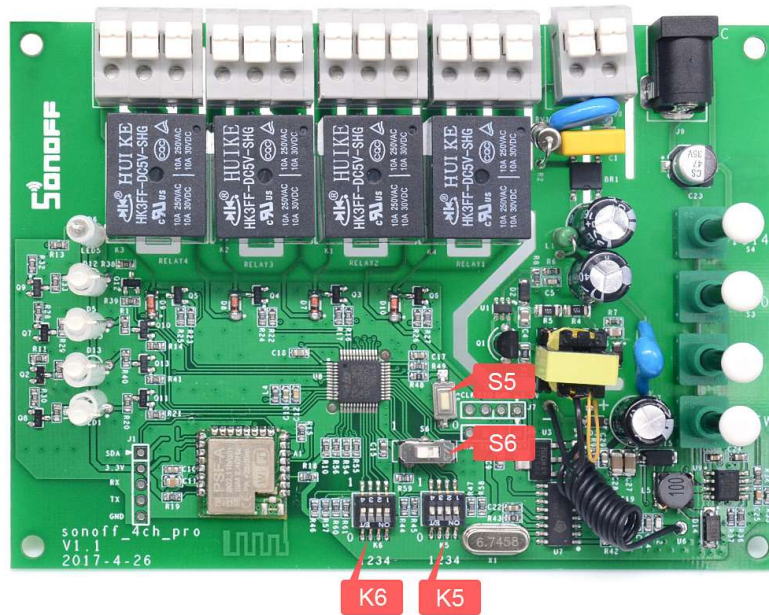

As you can see from the image, there are S5, S6, K6 and K5.

CAUTION: Please cut off the power supply before switching S5, S6, K5, K6. Whether you use DC or AC input, make sure you have unplugged the power plug every time!!! It's very dangerous if you don't cut off the power supply, and the new settings cannot be activated.

Work Mode Switch S6		
0	Interlock	CH1 to CH4
1	Self-locking/Inching	CH1 to CH4

Work Mode Switch K5			
Position	Status	Mode	Apply to
1	0	Inching	CH1
2	0	Inching	CH2
3	0	Inching	CH3
4	0	Inching	CH4
1	1	Self-locking	CH1
2	1	Self-locking	CH2
3	1	Self-locking	CH3
4	1	Self-locking	CH4

Note: Cut off the main supply before changing work mode.

S6 is interlock /inching&self-locking switch: Toggle to the right(0), it enters into interlock mode; Toggle to the left(1), it enters into inching &self-locking mode.

K5 is inching/self-locking switches: From left to right, there are 1, 2, 3, 4, correspondingly for channel 1 (CH1), channel 2 (CH2), channel 3 (CH3), channel 4 (CH4). Toggle the switch down (0), the corresponding channel enters into inching mode; Toggle the switch up (1), the corresponding channel enters into self-locking mode.

- Please note that if S6 is toggled to the right(0), your 4CH Pro is in interlock mode, it's invalid to set K5.

K6 is used to set the delay time for inching mode. From left to right there are 1, 2, 3, 4, correspondingly for CH1, CH2, CH3, CH4. Take Sonoff 4CH Pro for example, toggle all switches down (0000), the inching time will delay for 16s; Toggle all switches up (1111), the inching time will delay for 1s.

Please refer to the Sonoff 4CH Pro/Sonoff 4CH Pro R2's delay time setting list below:

Delay Time Switch K6		
Value	Delay	Apply to
0000	16s	CH1 to CH4
0001	15s	CH1 to CH4
0010	14s	CH1 to CH4
0011	13s	CH1 to CH4
0100	12s	CH1 to CH4
0101	11s	CH1 to CH4
0110	10s	CH1 to CH4
0111	9s	CH1 to CH4
1000	8s	CH1 to CH4
1001	7s	CH1 to CH4
1010	6s	CH1 to CH4
1011	5s	CH1 to CH4
1100	4s	CH1 to CH4
1101	3s	CH1 to CH4
1110	2s	CH1 to CH4
1111	1s	CH1 to CH4

4. RF Remote Settings

Learn with 433MHz RF Remote : Each gang can supports 1 RF key, which means each gang can only remember the RF key learned last time. Quickly press twice one of the switches below, then press one of the ABCD buttons on your RF Remote. If learned successfully, the button will lit up in red, and the corresponding status LED will blink in green for 4 times. You can press the button to turn on or turn off the corresponding channel.



Clear 433MHz Coding: S5 is 433MHz code clearing button, please press and hold it until the 4 LEDs lit up green and off.

5. APP Features

1. Use WiFi to remote control 4 devices separately.

Turn on/off by tapping on device icon. Device status will simultaneously display on the interface.

2. Share Control

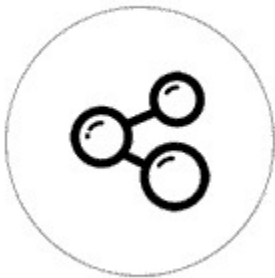

The owner can share the devices to other eWeLink accounts. While sharing devices, both should stay online on eWeLink. Because if the account you want to share is not online, he/she will not receive the invitation message.

How to make it possible? Firstly click **Share**, input the eWeLink account (phone number or email address) you want to share, tick the timer permissions (edit/delete/change/enable) you want to give, then click **Next**. The other account will receive an invitation message. Click **Accept**, the device has shared successfully. The other account will have access to control your device.

3. Timing



Supports max 8 enabled single/repeat/countdown timer to auto-turn on/off connected appliances.

4. Scene

Scene allows triggering on/off your devices automatically. Scene Settings is in the upper right corner of **Device List**. You can set up scenes or smart scenes to trigger on/off Sonoff 4CH Pro.

Users should select “Click to execute” in the condition, add different existing devices, name the scene and save it.

4. Problems and Solutions

Read the detailed [FAQ](#) on Itead Smart Home Forum. If below answers can't solve your problem, please submit a feedback on eWeLink.

1. My device has added successfully but stays “Offline”.

Answers: The newly added device need 1-2 min to connect to your router and the Internet. If it stays offline for a long time, please judge the problem by the wifi led status:

1.1. Wifi led quickly blinks one time and repeats, which means device failed to connect to the router. The reason may be you have entered wrong WiFi password or your device is too far away from the router, which causes a weak WiFi signal. The device can not be added to the 5G-wifi-router, only the 2.4G-wifi is OK. At last, make sure that your router is MAC-open.

1.2. Wifi led slowly blinks one time and repeats, which means the device has connected to router and server but failed to be added to device list. Then power on the device again, if it still not working, just add the device again.

1.3. Wifi led quickly blinks twice and repeats, this means the device has connected to the router but failed to connect to the server. Then please confirm your WiFi router works normally.

2. Why the APP can not find the device in pairing status?

Answers: That's because of your phone's cache. Please close the WLAN of your phone then open it after a minute. At the same time, please power off the device if you can, then power up to try again.

3. My WiFi is expired, can I connect the devices to LAN?

Answers: Currently this product does not support LAN or directly connect to hotspot. It must connect to the WiFi router with a normal network that can visit the Internet.